



GOOD PRACTICE GUIDE FOR HANDLING SOILS

Sheet 4:

Soil Replacement with Excavators and Dump Trucks

Issued by the Farming and Rural Conservation Agency, Cambridge

April 2000

MAFF FOREWORD

Standards of restoration of minerals and waste sites have steadily improved in recent years, with operators increasingly aware of their environmental responsibilities. The industry is putting forward more imaginative restoration concepts to a variety of afteruses, and is more aware than ever that it will be judged on the standard of that restoration, and the sustainability of the development.

Sustainable mineral development means balancing economic, environmental and social needs, whilst using resources wisely. The UK Strategy for Sustainable Development recognises the importance of safeguarding agricultural land to meet the needs of future generations, and minimising the loss of soils to new development*.

Improved restoration standards have sometimes enabled planning permission to be given for best and most versatile agricultural land to be worked for minerals, on the basis that it can be restored in a way that safeguards its long-term agricultural potential**. Inherent in these high standards of restoration is the requirement to handle soils in such a way that damage to their structure is minimised. It is the aim of this Guide to provide comprehensive advice on soil handling “Good Practice” to operators, soil moving contractors, consultants and planning authorities.

The Guide is in the form of 15 Sheets giving advice on soil stripping, the forming and taking down of soil storage mounds, and soil replacement operations using excavators, earth scrapers or bulldozers. There are also four Guidance Sheets on remedial works involving the removal of stones and damaging materials, and decompaction during the replacement operations.

This document should be cited as MAFF (2000), Good Practice Guide for Handling Soils (version 04/00). FRCA, Cambridge.

Any views expressed in the guidance are those of the consultant and do not necessarily represent the view of the Ministry of Agriculture, Fisheries and Food.

*(DETR, A Better Quality of Life, May 1999, paragraphs 6.66 and 8.50)

**MPG7 (November 1996, paragraph 3).

Acknowledgements

The Guide was written and prepared by Dr R N Humphries of Humphries Rowell Associates, Charnwood House, Loughborough, LE11 3NP, UK. The art work was by R Shenton of H J Banks & Co.

SHEET 4 SOIL REPLACEMENT WITH EXCAVATOR & DUMP TRUCK

The purpose of this Guidance Sheet is to provide a model method for best practice where soils are to be replaced by excavators and dump trucks. This Guidance Sheet comprises 7 pages of text, 4 figures and a user response form.

The model may need to be modified according to site conditions or requirements of the Planning Authority. Where this is the case, deviation from the model should be recorded with reasons. The guidance does not specify the type, size or model of equipment, but this should have been agreed as part of the planning conditions or as a reserved matter. The machines should be of a kind which will cause the minimum compaction whilst being operationally efficient (eg wide tracked), and must be well maintained at all times.

Persons involved in the handling of soils, overburden etc., and in the construction or removal of mounds or tips, must comply with the Health and Safety at Work Etc. Act 1974 and its relevant statutory provisions, and in particular those aspects which relate to the construction and removal of tips, mounds and similar structures. This requirement takes preference over any suggested practice in the Sheets.

The user of these guidelines is solely responsible for all liabilities that might arise. No liabilities are accepted for any losses of any kind arising from the use of this guidance.

This soil handling method uses back-acting excavators in combination with dump trucks (articulated or rigid bodied). An excavator is used to spread the soil tipped from dump trucks used for transportation to replacement areas.

The soil handling method can affect the agricultural quality of the restoration through severe soil deformation (compression and smearing). This is primarily caused through trafficking, the effects of which increases with increasing soil wetness.

The advantage of this model method, if correctly carried out, is that it should avoid severe deformation of the soil as trafficking is minimised. Consequently, there should normally be no need for decompaction treatment during the replacement operation, unless the soils are in a compacted state following stripping or storage. Where compaction occurs at replacement this will need treatment during the replacement process. Also where required, it will be necessary to integrate the removal of stones or damaging materials with the replacement process. Both decompaction and removal of materials are covered in separate Guidance Sheets (16-19).

The early installation of under drainage is strongly recommended. Where required this should either be undertaken sequentially during the replacement of the soils or in the early aftercare period. Until drains are installed it is recommended that the restored land is sown and managed as grassland.

The key operational points to ensure avoidance of severe soil deformation are as follows:

- (i) To minimise compaction:
 - the dump trucks must only operate on the 'basal'/non-soil layer, and their wheels must not on any circumstances run on to the soil layer(s).
 - the excavator must only operate on the basal layer.
 - the adoption of a bed/strip system avoids the need for the trucks and excavator to travel on the soil layers.
 - the machines are to only work when ground conditions enable their maximum operating efficiency.
 - if compaction has been caused, then measures are required to treat it (see Sheets 18 & 19).

- (ii) To minimise soil wetness and rewetting:
- the bed/strip system provides a basis to regulate the exposure of lower soil layers to periods of rain and a means of maintaining soil moisture contents. The soil profile within the active strip should be completed to the topsoil layer before rainfall occurs and before replacement is suspended.
 - measures are required to protect the face of the soil layer from ponding of water and maintain the basal layer in a condition capable of supporting dump trucks.

The Replacement Operation

- 4.1 The area to be restored is to be protected from in-flow of water, ponding etc. Wet sites must be drained in advance. Before the operation starts the basal layer should be to level and clean.
- 4.2 Prior to commencing operations a Meteorological Office forecast should be obtained which gives reasonable confidence of soil replacement proceeding without interruptions from rainfall events. If significant rainfall occurs during operations, the replacement must be suspended, and where the soil profile has been started it should be replaced to topsoil level. Replacement must not restart unless the weather forecast is expected to be dry for at least a full day.
- 4.3 All machines must be in a safe and efficient working condition at all times. The machines are to only work when ground conditions enable their maximum operating efficiency. The operation should only be carried out when the basal layer supports the machinery without ruts or is capable of repair/maintenance. The operation is to be suspended before traction becomes a problem or the integrity of the basal layer and haul routes fails.

- 4.4 The operation should follow a detailed replacement plan showing soil units to be replaced, haul routes and the phasing of vehicle movements. The soil units should be defined on the site with information to distinguish types and layers, and thickness. Detailed daily records should be kept of operations undertaken (including the removal of stones and other damaging materials, and the results of any assessment of the need for additional decompaction and effectiveness of decompaction work undertaken), and site and soil conditions.
- 4.5 The excavator and dump trucks are only to stand, work and travel on the basal/formation layer.
- 4.6 The soil layers above the base/formation layer are to be replaced in sequential strips with the subsoil layer(s) replaced first, followed by the topsoil layer; each layer being replaced to the specified thickness. The next strip is not to be started until the profile in the current strip is completed. This is often referred to as the 'bed or strip system'. The system involves the progressive sequential laying of the materials in strips across the area to be restored (Figure 4.1).
- 4.7 The initial strip width and axis is to be demarcated. Strip width is determined by excavator boom length less the stand-off to operate; typically about 5-8m. Effective boom length can also reduce with profile heights greater than 1m; at 1.5m the effective reach of the standard boom may result in only 2m wide strips. A wide bucket with a blade and not teeth should be used to spread the soil.
- 4.8 Reverse dump truck up to edge of the current strip and tip the lowest layer (subsoil) soil, without the wheels riding onto the strip (Figure 4.1). The dump truck should not drive away until all the soil is deposited within the strip without spillage over the basal layer; this may require assistance from the excavator to 'dig away' some of the tipped soil (Figure 4.2). The excavator is to spread the tipped soil to full thickness by digging, and the pushing and

pulling action of bucket. Each load of soil should be spread following tipping, before another is tipped. Should the spread soil comprise of large blocks (>300mm), normally these should be broken down by using the excavator bucket to 'slice' the blocks into smaller pieces (see Sheet 18) before the next load is spread. The process is repeated from left to right until the strip is completely covered with the required depth of the soil layer (Figure 4.3). Alternatively, decompaction by ripping should be undertaken once the strip is complete (see Sheet 19). Decompaction work must be completed before the next soil layer is placed.

- 4.9 Level boards and soil pits should be used to verify soil thickness in each strip and overall levels. Allowances (ie. a bulking factor) should be made for any settlement that may take place of the replaced loose soil.
- 4.10 Where stones are to be removed as part of the replacement process, normally the method described in Sheet 16 should be used once the strip is complete. An alternative method and one suited to removing potentially damaging materials (eg wire ropes) is described in Sheet 17. These operations must be completed before the next soil layer is placed.
- 4.11 On completion of the lowest (subsoil) layer, repeat the process spreading the next layer (subsoil/topsoil) (Figure 4.4). Tip the soil by reversing to the outer edge of strip/soil previously laid, but without the truck wheels riding onto the already placed layer. The soil is to be spread by the excavator to full thickness by digging, and the pushing and pulling action of bucket described above, and undertaking any necessary decompaction work and removal of stones if using Sheets 16 to 19. Repeat the process progressively (left to right) along the strip and undertake any removal of damaging materials or decompaction. Level boards should be used to verify soil thickness in strip and overall levels.
- 4.12 Where the profile is made up of further soil layers (subsoil/topsoil) the process outlined above should be repeated on completion of the strip.

- 4.13 On completion of topsoil layer the processes outlined above should be repeated for the next strips until the area to be restored is completed. Before the operation starts the basal layer should be to level and clean.
- 4.14 At the end of each day the current strip must be completed if rain is forecast. If during a day it is evident that a full strip cannot be completed, then only start part of a strip; this too must be completed.
- 4.15 At the end of each day, or during the day if interrupted by rain, make provisions to protect base of restored strip from ponding/runoff by sumps and grips, and also clean and level the basal layer. At the start of each day ensure there is no ponding in the current strip or operating areas, and the basal layer is to level with no ruts.

Operational Variations

- 4.16 When the replaced soil profiles reach about 0.6-1m in height it may not be possible to discharge the load from some dump trucks directly onto the previously placed layers because of the height of the dump truck body. The preferred solution is to tip the soil against the partially completed profile as heaps without the dump trucks rising onto or reversing into the placed material. The soil material is then lifted by the excavator onto the profile. It is considered preferable to accept some limited soil losses rather than to contaminate the topsoil with overburden. The loss of topsoil is minimised if the basal/ formation layer is kept to level and clean.
- 4.16 If the basal/formation layer is to be decompacted, before any soil material is placed, each strip is to be firstly decompacted before the subsoil layer is replaced using either methods described in Sheets 18 or 19. The basal layer must only be decompacted in the strip required for soil replacement, and must



only be prepared on the day of soil placement. During this process it may be necessary to use Sheets 16 or 17 for the removal of stones or damaging materials from the decompacted basal layer.

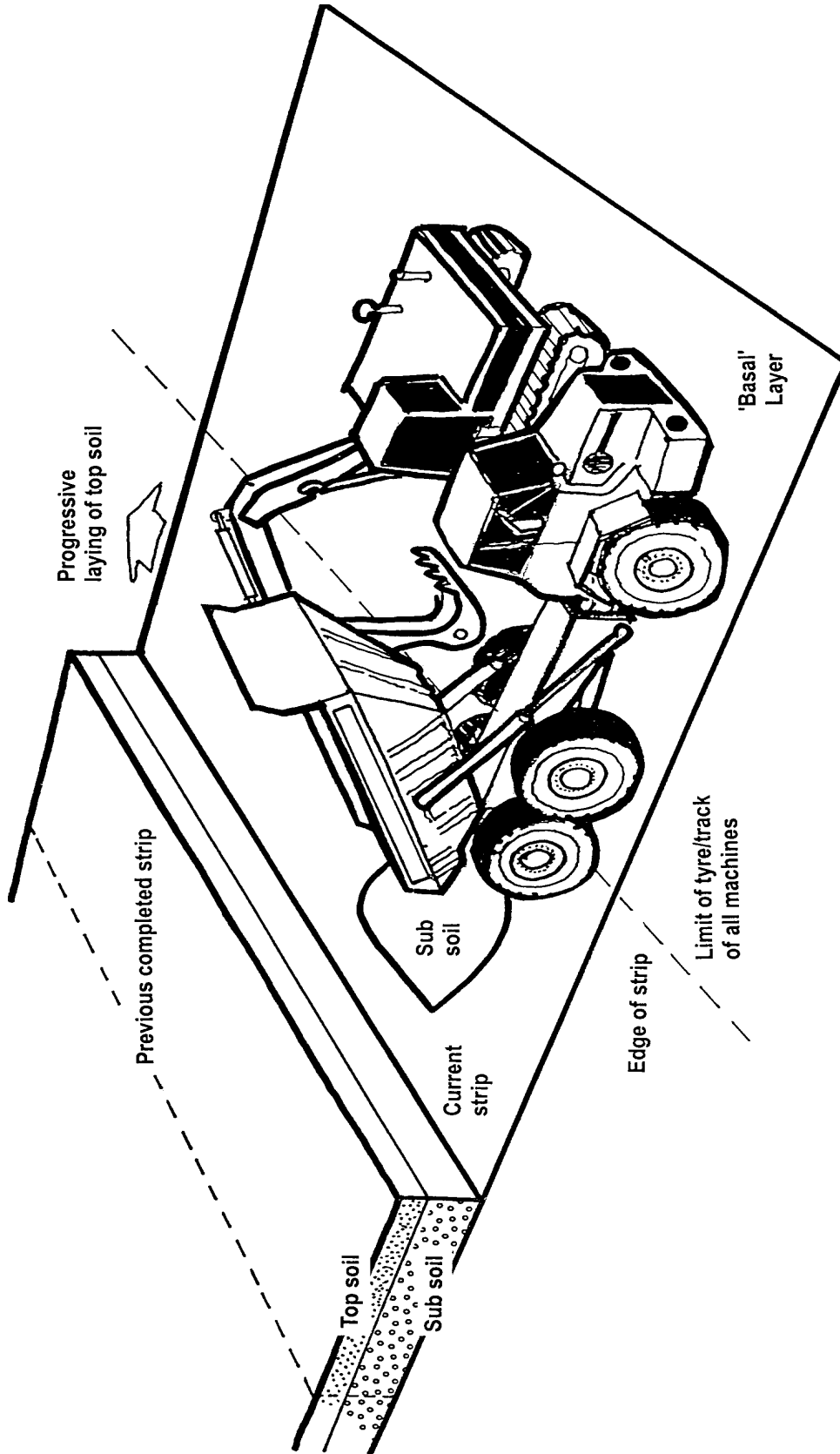

**Figure 4.1 Soil replacement with excavators and dump trucks:
 Sub soil layer**

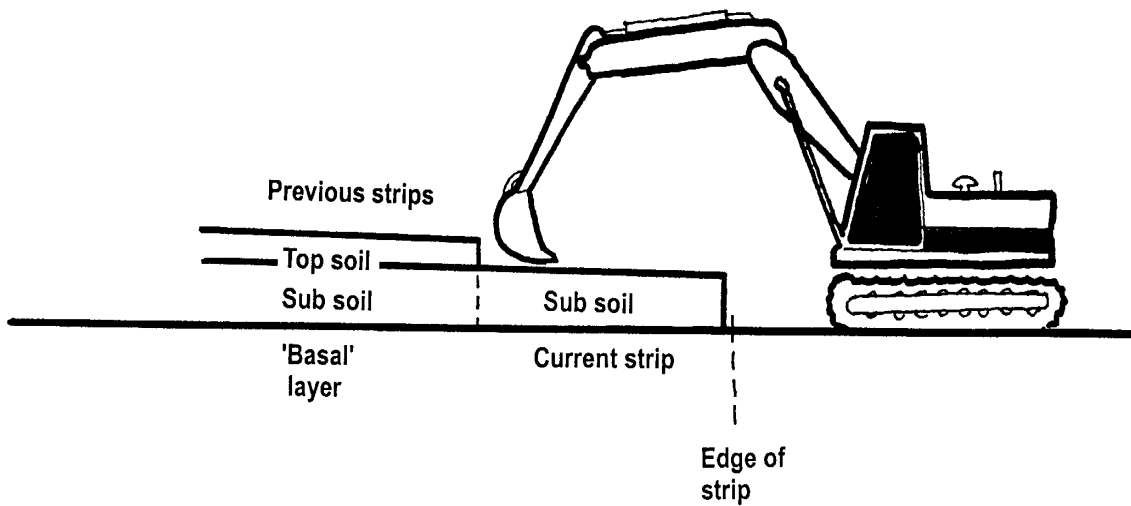
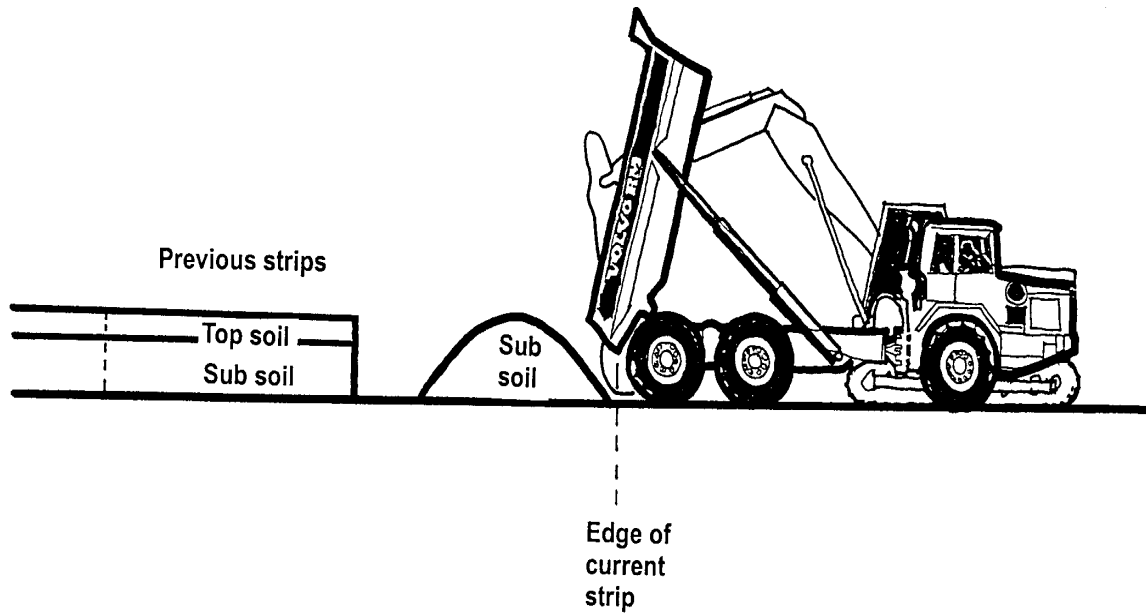

**Figure 4.2 Soil replacement with
 excavators - dump trucks
 Sub soil layer**

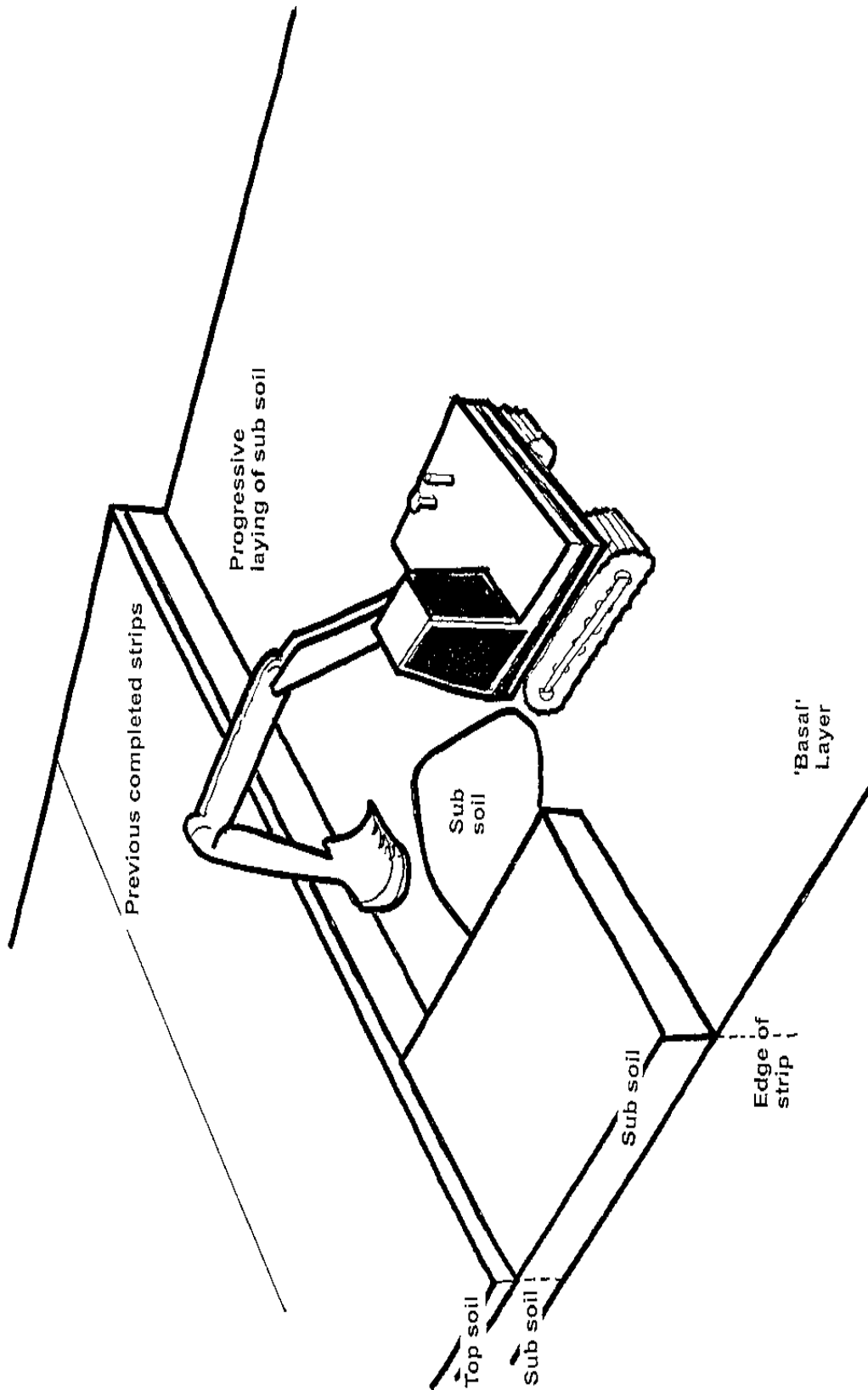

**Figure 4.3 Soil replacement with excavators and dump trucks:
 Sub soil progressively laid**

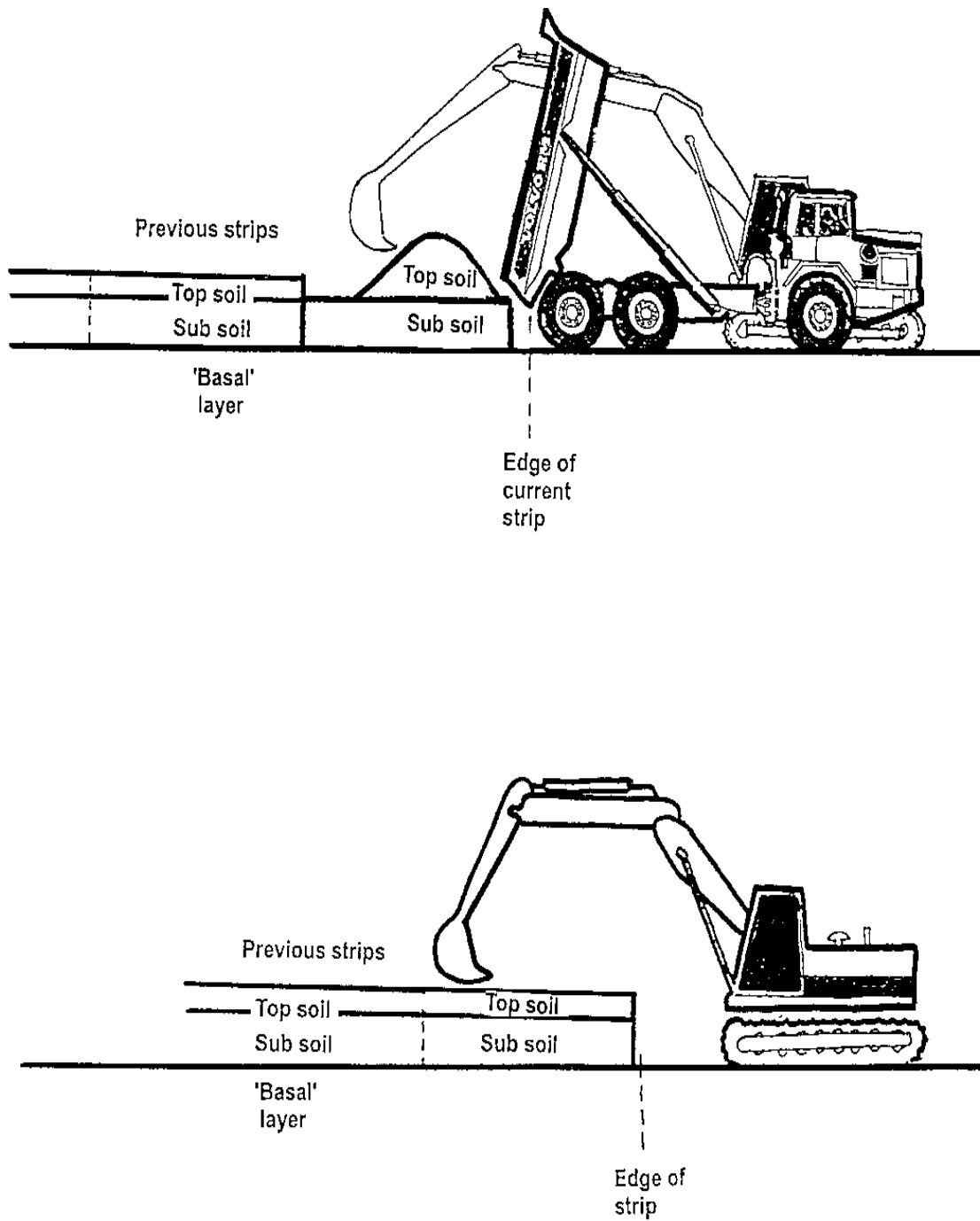

**Figure 4.4 Soil replacement with excavators and dump trucks:
Top soil layer**

SHEET 4

Version: 04/00

FEEDBACK

It would be most helpful in assessing access to this Guidance, the use made of it and its further development if the following could be completed and returned to the FRCA:

<u>Organisation</u>	<input type="text"/>	
<u>Contact Name</u>	<input type="text"/>	
<u>Telephone/e-mail</u>	<input type="text"/>	<u>Date</u> <input type="text"/>

Is the Guidance to be used generally or for specific site/works?

General **Specific site**

If specific site – please identify

Name **County** **Country**

How was the Guidance obtained?

Internet **FRCA** **Other**

If other – please identify source

Source of Guidance

When was the Guidance obtained?

Month **Year**

Please provide any helpful comment/experience which may benefit the Guidance (use additional sheets if necessary)

<input type="text"/>
<input type="text"/>

Please copy and return to: M Stephen, Farming and Rural Conservation Agency, Rural Development Team, Government Buildings, Block C, Brooklands Avenue, Cambridge CB2 2BL, UK